



TELEPHONE:

(902)542-7478

FAX:

(902)542-7479

e-mail:

info@britcycle.com

website:

www.britcycle.com

604 DAVISON STREET, RR3 WOLFVILLE, NOVA SCOTIA, B4P 2R3, CANADA

146 PORTER STREET, HACKENSACK, NEW JERSEY, 07601, USA

Q.P.D.

Atlas, Pre-1975 Commando & Pre-Unit Triumph Belt Drive Instructions

- 1) Remove all parts from primary.
- 2) Clean oil and all foreign particles from primary.
- 3) Loosen gearbox; move forward.
- 4) Place front pulley on crankshaft; tighten.
- 5) Place clutch housing on mainshaft; tighten.
- 6) Using proper tool, invert diaphragm; remove pushrod.
- 7) With diaphragm in place, install large clip, making certain it is seated.
- 8) Install pushrod.
- 9) Remove all adjustment at handlebar.
- 10) Turn adjusting screw inward until it touches pushrod.
- 11) Back out until it is not touching rod.
- 12) Pull back transmission for correct tension, making certain clutch housing is in line with front pulley.
- 13) Front flange should be set tight.
- 14) All adjustment can be made at clutch lever, enough that the pushrod is free.
- 15) After running, you may want to readjust the clutch.

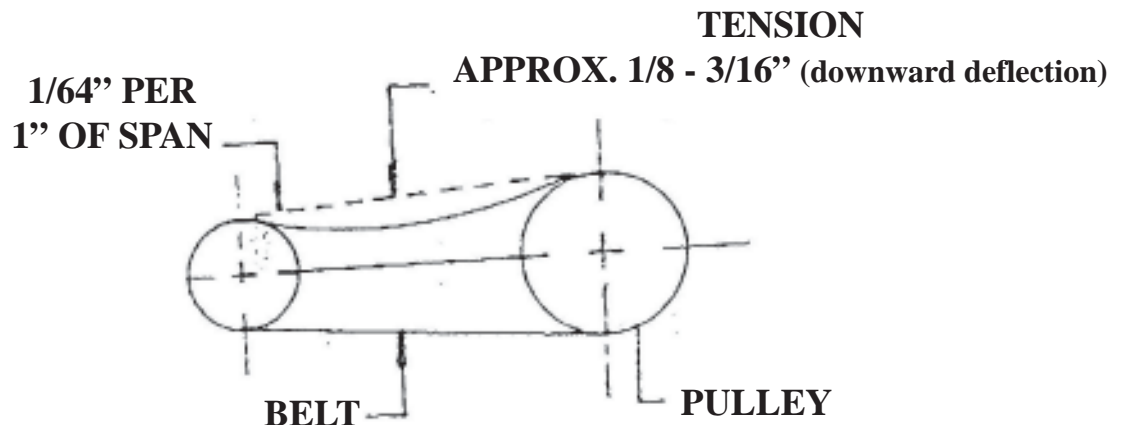

IMPORTERS AND DISTRIBUTORS OF PARTS AND ACCESSORIES
FOR CLASSIC TRIUMPH, BSA AND NORTON MOTORCYCLES
HELPING TO KEEP BRITISH MOTORCYCLES ON THE ROAD SINCE 1977!
