

DISMANTLING

1. Remove points cover and battery cover. Remove the battery.
2. Disconnect coils. (Leave HT leads in place).
3. Remove the 3 contact breaker wires from their connections and remove the complete contact breaker plate as an assembly. Remove the advance/retard unit from the camshaft taper.
4. Remove the starter relay from the bottom of the battery carrier.
5. Remove and disconnect the condenser (capacitor) pack.

ASSEMBLY

Screw the pick-up backplate onto the engine using the bottom screw and the L.H. screw. The backplate should be in the middle of its adjustment slots and it may be necessary to use the extra washers supplied in the kit. Fit the reluctor, finger tight only, into the camshaft taper and set the 0.2-0.3 mm. gap. It is unnecessary to slacken the pivot screw to adjust the air gap. Set any cylinder at 38° B.T.D.C. on the compression stroke, using the timing marks on the alternator. Turn the reluctor in the taper until it traps the 5 mm. timing spacer as shown on the diagram. Lock up the centre bolt of the reluctor and check the 0.2-0.3 mm. air gap.

The amplifier is now mounted under the battery carrier and this is easier if the chain guard is removed. A socket with a long extension is required to simplify this. Now position the amplifier under the battery carrier from the L.H. side of the machine. The cable outlet must face rearwards, but bring the cables forward over the back of the amplifier before bolting on. Slide the vertical bracket up between the oil tank and the flange on the R.H. end of the battery carrier. Hook the bracket on to this flange and put the M6 x10 counter-sunk screw through the existing hole in the battery carrier and through the amplifier bracket. Fit and tighten the M6 nut and spring washer. Check that the amplifier is clear of the oil tank.

WIRING

Whilst the wiring of this Ignition System is straight forward care is needed to ensure the correct connections are made otherwise a component may be damaged. Basically, two 6 volt coils wired in series are connected in parallel with a 6 volt coil in series with a ballast resistor. The coils and ballast resistor are all original equipment on the bike.

The ballast resistor has a white-yellow wire to one terminal, this goes to the black ignition feed and two white-blue wires to the other terminal. However, to confuse the issue some machines have a single white-yellow wire to both ballast resistor terminals. A voltmeter or 12 volt bulb will be needed to identify the live wire for connection to the black wire.

The double white-yellow earth link goes to the left hand coil positive terminal, with the short link to the amplifier case and the long one to a good earth point.

Connect the pick-up to the contact breaker wires using the terminal post fitted to the back-plate. It is designed to insulate all the terminals from the plate and stud and to insulate one pair of eyelets from the other pair. Fit the contact breaker eyelets so that the black-red connects to the black and the black-white connects to the white. Ensure that two fibre washers separate the 2 pairs of eyelets and tighten the top nut.

Tap redundant lucar terminals out of the way and so they will not contact another terminal or earth.

NOTES - Run the engine and adjust the fully advanced (38°) timing, using a stroboscope at 6,500-6,000 R.P.M. This is an easy operation with two people, but the engine should only be taken up to this speed momentarily as it is not under load.

BRITISH CYCLE SUPPLY

Call (902)542-7478

Fax (902)542-7479

info@britcycle.com

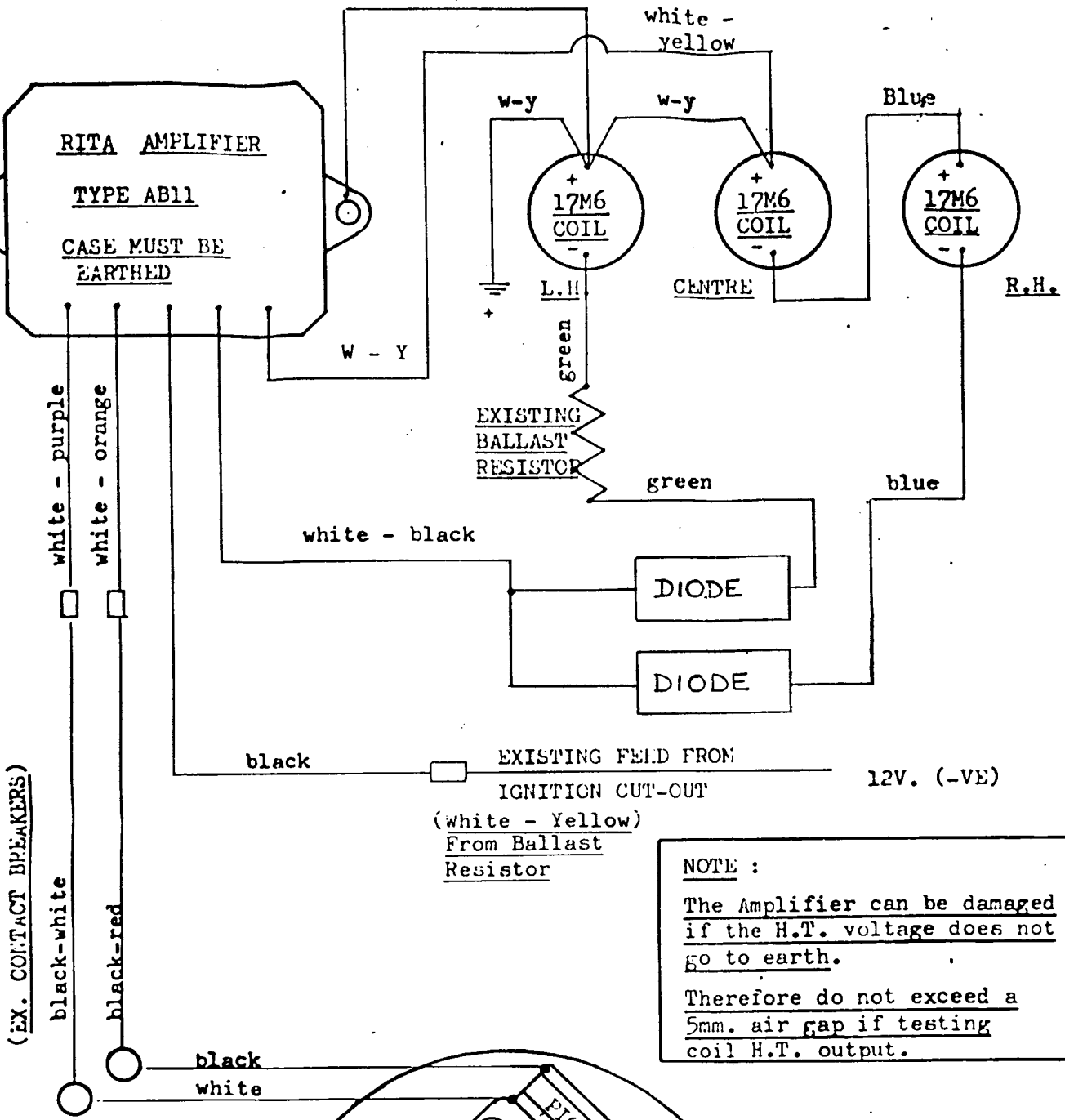
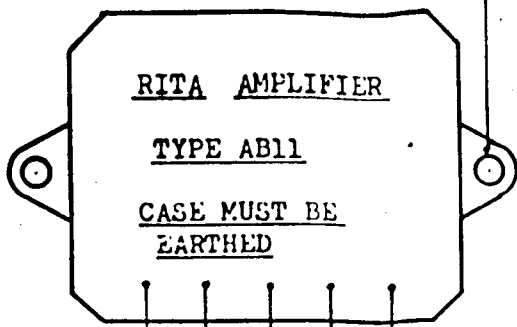

NOTE :
The Amplifier can be damaged if the H.T. voltage does not go to earth.
Therefore do not exceed a 5mm. air gap if testing coil H.T. output.

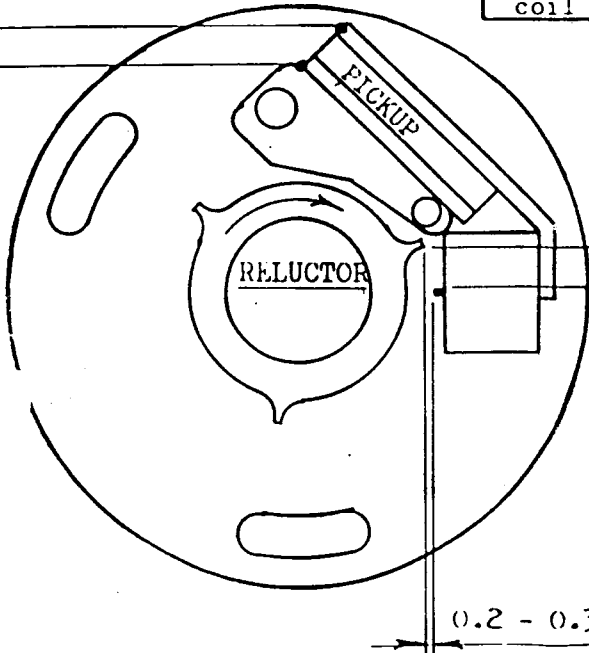

RITA SYSTEM FOR
TRIUMPH TRIDENT T.160
ISSUE 3

BRITISH CYCLE SUPPLY
Call (902)542-7478
Fax (902)542-7479
info@britcycle.com